

GENERAL

The WATTS Cazzaniga pressure reducing valves **Series DRV, DRVN and DRVD** are of balanced seat type.

This means that the inlet pressure, when acting on the two openings A and B with the same section, is compensated. Therefore it does not exert any force on the pin-plug system when the degree of valve opening changes.

Instead, the outlet pressure acts on the diaphragm and hence on the pin-plug system which, therefore, is subjected to two opposing forces, namely: the force exerted by the outlet pressure tending to close the plug, and the pressure exerted by the spring tending to open it.

This results in the pressure reducing valve acting like a balanced seat type having the outlet pressure almost unaffected by variations in upstream pressure.

SETTING

The difference between the downstream pressure P_2 measured with zero flow rate and the same pressure measured with a general flow rate Q represents the pressure drop DP across the pressure reducing valve. It depends on the flow rate as shown in the pressure drop diagrams.

If it is required for the upstream pressure not to exceed a given value P_2 , this should be adjusted to value P_2 when the flow rate is zero. At flow rate Q , the downstream pressure will be below the value P_2 by an amount equal to pressure drops DP .

When the pressure reducing valve is installed to ensure that the downstream pressure reaches a given value P_2 at a certain flow rate Q , this pressure should be adjusted to value $P_2 + DP$ when the flow rate is zero. At flow rate Q the downstream pressure will be equal to P_2 .

SIZING

The valve selection criterion consists in determining the diameter so that the speed of the fluid does not reach excessive levels, at nominal flow rate, thus causing excessive pressure drops and noisy effluent which are transmitted to the supply main. The flow rate-speed diagrams provide a guide for selecting the valve diameter in the case of liquids (see water) or gases with pressures of 8 to 10 bar (see air).

EXAMPLES OF SIZING

Example 1 (cavitation)

Pressure reducing valve with:

Inlet pressure $P_1 = 14$ bar

Outlet pressure $P_2 = 3$ bar

From the cavitation diagram it can be seen that the pressure reducing valve works constantly in the red zone. To avoid rapid deterioration, two valves can be used, one connected upstream to the other.

Upstream valve: pressure change from 14 to 6 bar (green zone)

Downstream valve: pressure change from 6 to 3 bar (green zone).

Example 2 (flow rate)

Pressure reducing valve DRV/N with:

Inlet pressure (min.) $P_1 = 8$ bar

Outlet pressure $P_2 = 4$ bar

Max. flow rate $Q = 50$ l/min

From the flow rate-speed diagram it can be seen that a diameter of 20 or 25 can be used. The pressure drop diagram shows that in the two cases:

DRV20/N $Q = 50$ l/min $DP = 1.1$ bar

DRV25/N $Q = 50$ l/min $DP = 0.68$ bar



DRV

Diaphragm pressure reducing valve with single balanced seat. Ensures min. pressure drops with high flow rates. Downstream pressure set by means of the setting screw (4) and is locked with lock nut (3)

Part No.

SIZE

0501115	1/2"MM
0501120	3/4"MM
0501125	1"MM
0501132	1.1/4"MM
0501140	1.1/2"MM
0501150	2"MM



DRVN

Like DRV, but with pressure gauge Ø50 for reading downstream pressure

Part No.

SIZE

0501315	1/2"MM
0501320	3/4"MM
0501325	1"MM
0501332	1.1/4"MM
0501340	1.1/2"MM
0501350	2"MM

Flow rate/speed diagram DRV - DRVN

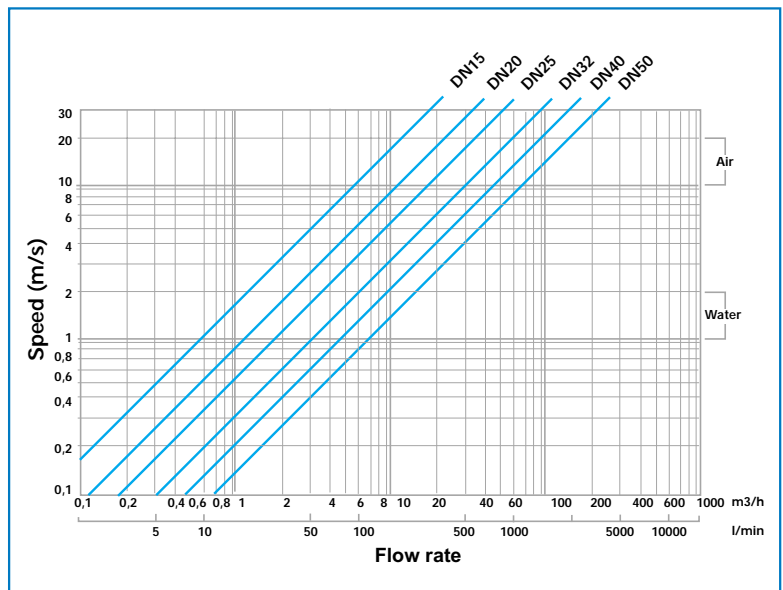

Flow rate/speed diagram DRVD

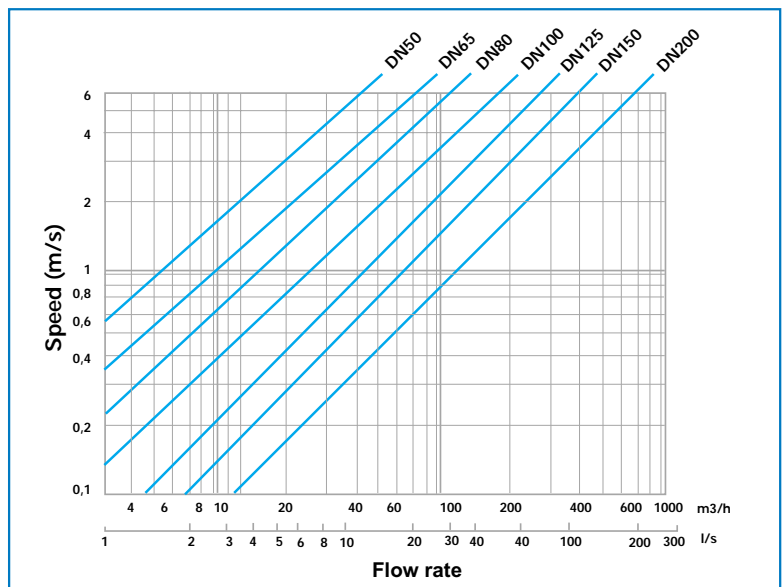

CAVITATION

The cavitation diagram shows three zones of valve operation in relation to the upstream and downstream pressures, namely:

zone C: normal duty, no cavitation

zone B: medium duty, possible cavitation

zone A: heavy duty, the valve cavitates.

Continuous operation in the red cavitation zone causes rapid deterioration of the internal parts. If the pressure reducing valve is to be used in the red zone, please contact the WATTS Cazzaniga Engineering Department.

APPLICATION

Water, air and neutral (non aggressive) gases.

APPROVALS

- DVGW approval (Arbeitsblatt W 375)
- LGA approval (DVR15 to 32) according to DIN 4109 class I (noise below 20 dB)
- SVGW approval (W/TPW101).
- TIN approval (Poland)
- CSTB approval (NF P 43-006) (DRV15, DRV20).
- KTW certification for all materials in contact with water.

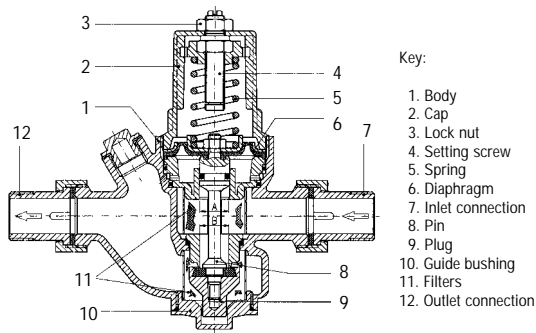

Overall dimensions (mm)

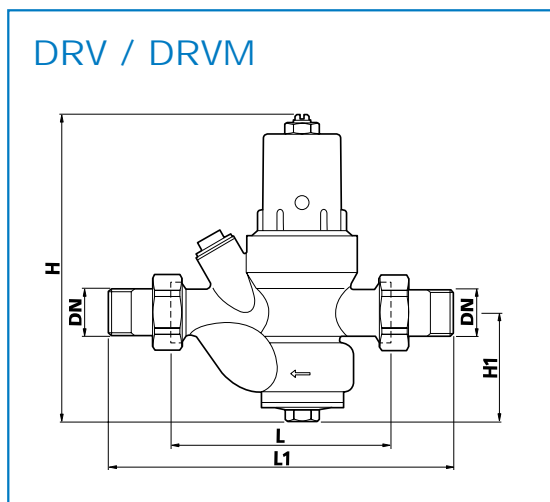

DRV / DRVM

SIZE	L	L1	H	H1
1/2"	97	152	135	48
3/4"	110	171	155	58
1"	120	191	182	66
1.1/4"	140	211	227	75
1.1/2"	160	246	255	82
2"	175	261	262	88

Cavitation diagram

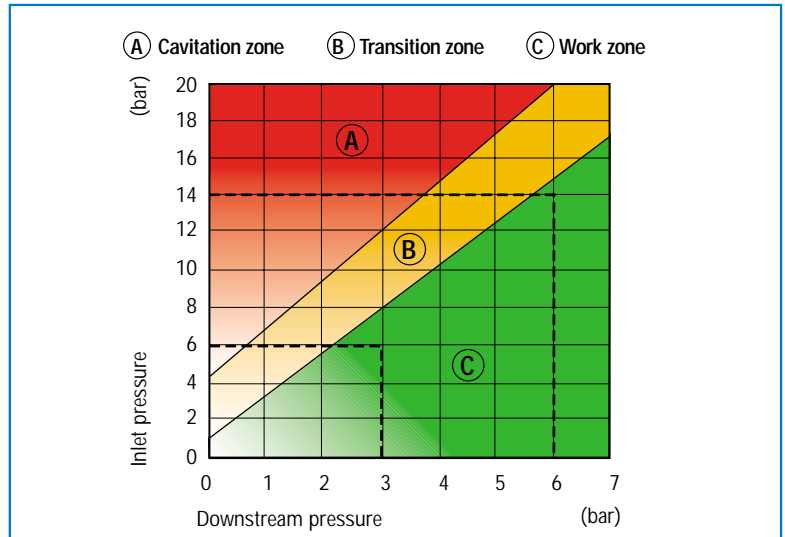

TECHNICAL CHARACTERISTICS

Max. upstream pressure	25 bar
Downstream pressure (outlet)	1.5 to 6 bar
Connections	to M / M tailpiece
Downstream pressure adjustment (screw 4)	Clockwise rotation: increase in pressure Anti-clockwise pressure: decrease in pressure
Downstream pressure gauge (DRV-M only)	Pressure gauge Ø50, scale 0 to 6 bar
Max. operating temperature	70° C

DESIGN FEATURES

Body	Shot-blasted brass OT58
Cap	Shot-blasted brass OT58
Plug	Brass OT58
Inlet / outlet connections	Brass OT58
Diaphragm	NBR with nylon fabric
Seal and O-ring	NBR
Spring	Galvanized steel
Setting screw and lock nut	Brass OT58
Filters	Stainless steel

Flow rate - Pressure drop diagram

